

## DESIGN AND DEVELOPMENT OF A STEEL-BASED BULLOCK CART

### Brief write up

Bullock Carts have been used especially in rural India as primary means of transporting food grains, crops and etc since very early ages. Unfortunately, it could not avail the advantages of technological development as being taken place in other areas of transportation. Bullock carts remain depending on concept and design of very primitive stage over generations.

CMERI will develop a Steel Based Bullock Cart as an efficient, cost effective transporting means in rural India.

Development of steel based bullock cart shall have several advantageous features over the convention bullock cart with design of primitive age. Development of bullock cart is focused on the objectives as stated below:

1. Efficient means of transportation in rural India.
2. Weight comfortable to Cart carrying animals.
3. Improvement of the strength.

A 3D-model of a Steel Bullock Cart is shown below:

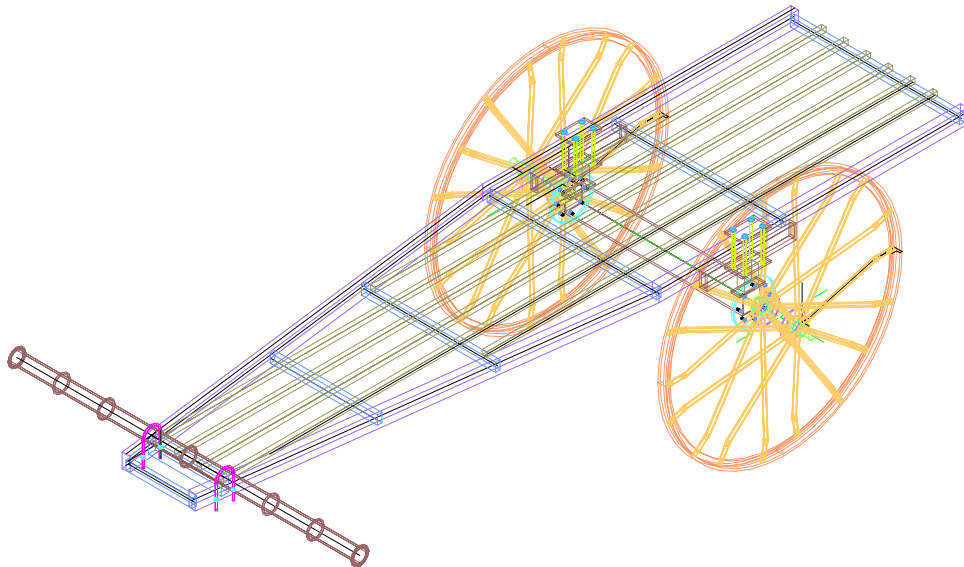

**3D MODEL OF A BULLOCK CART**